

01 - 07.1

03.03.GB

**LDM valves
with Belimo actuators**



Kv coefficient calculation

Calculation itself is carried out with respect to conditions of regulating circuit and operating medium according to equations mentioned below. Control valve must be designed to be able to regulate maximal flow quantity at given operating conditions. At the same time it is necessary to check whether minimal flow quantity can be even regulated or not.

Condition is the following ratio $r > Kvs / Kv_{min}$

Because of eventual minus tolerance 10% of Kv_{100} against Kvs and requirement for possible regulation within range of maximal flow (decrement and increase of flow), producer recommends to select Kvs value higher than maximal operating Kv value:

$$Kvs = 1.1 \div 1.3 Kv$$

It is necessary to take into account to which extent Q_{max} involve "precautionary additions" that could result in valve oversizing.

Relations of Kv calculation

	Pressure drop $p_2 > p_1/2$ $\Delta p < p_1/2$	Pressure drop $\Delta p \geq p_1/2$ $p_2 \leq p_1/2$
Liquid	$\frac{Q}{100} \sqrt{\frac{\rho_1}{\Delta p}}$	
Gas	$\frac{Q_n}{5141} \sqrt{\frac{\rho_n \cdot T_1}{\Delta p \cdot p_2}}$	$\frac{2 \cdot Q_m}{5141 \cdot p_1} \sqrt{\rho_n \cdot T_1}$
Superh. steam	$\frac{Q_m}{100} \sqrt{\frac{v_2}{\Delta p}}$	$\frac{Q_m}{100} \sqrt{\frac{2v}{p_1}}$
Sat. steam	$\frac{Q_m}{100} \sqrt{\frac{v_2 \cdot x}{\Delta p}}$	$\frac{Q_m}{100} \sqrt{\frac{2v \cdot x}{p_1}}$

Above critical flow of vapours and gases

When pressure ratio is above critical ($p_2/p_1 < 0.54$), speed of flow reaches acoustic velocity at the narrowest section. This event can cause higher level of noisiness. Then it is convenient to use a throttling system ensuring low noisiness (multi-step pressure reduction, damping orifice plate at outlet).

Dimensions and units

Marking	Unit	Name of dimension
Kv	$m^3 \cdot h^{-1}$	Flow coefficient under condition of units of flow
Kv_{100}	$m^3 \cdot h^{-1}$	Flow coefficient at nominal stroke
Kv_{min}	$m^3 \cdot h^{-1}$	Flow coefficient at minimal stroke
Kvs	$m^3 \cdot h^{-1}$	Valve nominal flow coefficient
Q	$m^3 \cdot h^{-1}$	Flow rate in operating conditions (T_1, p_1)
Q_n	$Nm^3 \cdot h^{-1}$	Flow rate in normal conditions (0°C, 0.101 Mpa)
Q_m	$kg \cdot h^{-1}$	Flow rate in operating conditions (T_1, p_1)
p_1	MPa	Upstream absolute pressure
p_2	MPa	Downstream absolute pressure
p_s	MPa	Absolute pressure of saturated steam at given temperature (T_1)
Δp	MPa	Valve differential pressure ($\Delta p = p_1 - p_2$)
ρ_1	$kg \cdot m^{-3}$	Process medium density in operating conditions (T_1, p_1)
ρ_n	$kg \cdot Nm^{-3}$	Gas density in normal conditions (0°C, 0.101 Mpa)
v_2	$m^3 \cdot kg^{-1}$	Specific volume of steam when temperature T_1 and pressure p_2
v	$m^3 \cdot kg^{-1}$	Specific volume of steam when temperature T_1 and pressure $p_1/2$
T_1	K	Absolute temperature at valve inlet ($T_1 = 273 + t_1$)
x	1	Proportionate weight volume of saturated steam in wet steam
r	1	Rangeability

Flow characteristic selection in regard of valve stroke

To make right selection of valve flow characteristic, it is suitable to carry out checking of what stroke values will be reached in different operation states. We recommend to carry out such checking at least for minimal, nominal and maximal flow rates. The principle for flow characteristic selection is to avoid, if possible, 5÷10% of the beginning and end of the valve stroke range.

To calculate valve stroke at different operating conditions with different types of flow characteristics is possible with the advantage of using LDM's calculation programme VALVES. The programme serves for complete design of valve from Kv calculation to specification of a concrete valve with its actuator.

Valve flow characteristics

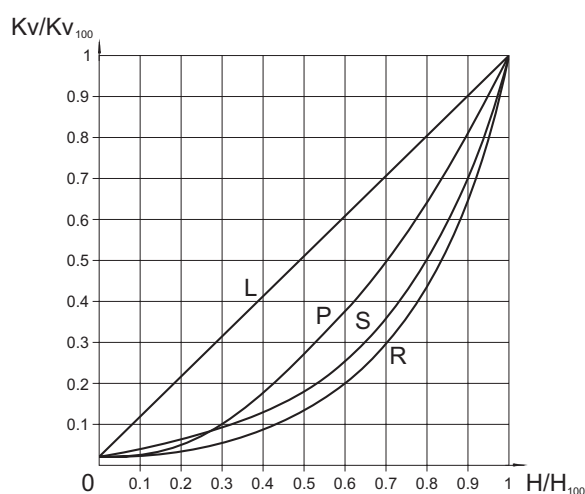

- L - linear characteristic
 $Kv/Kv_{100} = 0.0183 + 0.9817 \cdot (H/H_{100})$
- R - equal-percentage characteristic (4-percentage)
 $Kv/Kv_{100} = 0.0183 \cdot e^{(4 \cdot H/H_{100})}$
- P - parabolic characteristic
 $Kv/Kv_{100} = 0.0183 + 0.9817 \cdot (H/H_{100})^2$
- S - LDM spline® characteristic
 $Kv/Kv_{100} = 0.0183 + 0.269 \cdot (H/H_{100}) - 0.380 \cdot (H/H_{100})^2 + 1.096 \cdot (H/H_{100})^3 - 0.194 \cdot (H/H_{100})^4 - 0.265 \cdot (H/H_{100})^5 + 0.443 \cdot (H/H_{100})^6$

Principles for plug type selection

V-ported plugs should not be used in above - critical differential pressures with inlet pressure $p_1 \geq 0,4$ MPa and for regulation of saturated steam. In these cases we recommend to use a perforated plug. The perforated plug should be also used always when cavitation may occur due to a high differential pressure value or valve ports erosion caused by high speed of process medium flow. If the parabolic plug is used (because of small Kvs) for pressures $p_1 \geq 1,6$ MPa and above - critical differential pressures, it is necessary to close both plug and seat with a hard metal overlay, i.e. stellite trim.

Packing - O -ring EPDM

Packing is designed for non-aggressive media with temperature from 0° to 140° C. Packing excels with its reliability and long time tightness. It has ability of sealing even if the valve stem is a bit damaged. Low frictional forces enables valve to be actuated with a low-linear-force actuator. Service life of sealing rings depends on operating conditions and it is more than 400 000 cycles on average.

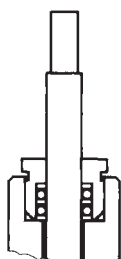

Applied to RV 102, RV 103

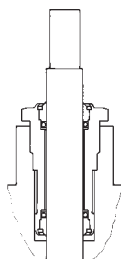

Applied to RV 2xx

Packing - DRSpack® (PTFE)

DRSpack® (Direct Radial Sealing Pack) is a packing with high tightness at both low and high operating pressure values. It is the most used type of packing suitable for temperatures ranging from 0° to 260° C. The pH range is from 0 to 14. The packing enables using of actuators with low linear force. The design enables an easy change of the whole packing. The average service life of DRSpack® is more than 500 000 cycles.

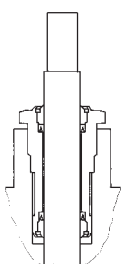

Service life of bellows packing

Bellows material	Temperature				
	200°C	300°C	400°C	500°C	550°C
1.4541	100 000	40 000	28 000	7 000	not applicable
1.4571	90 000	34 000	22 000	13 000	8 000

Values specified in the table above show minimal guaranteed number of cycles with the valve full stroke when the bellows is fully lengthened and pressed. In regulation, when the valve

Packing - Bellows

Bellows packing is suitable for low and high temperatures ranging from -50° to 550° C. Bellows ensures absolute tightness to environment. Packing is equipped with safety PTFE packing as standard to prevent medium from leaking in case of damage to bellows. Intensive linear forces are not required.

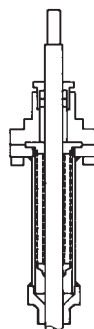

Application of bellows packing

Bellows packing is suitable for applications with very aggressive, toxic or other dangerous media that require absolute tightness to environment. In such case, it is necessary to check compatibility of used body material as well as the valve inner parts material with process medium. It is recommended to use bellows with safety packing preventing medium from leaking in case of damage to bellows when there is an extremely dangerous process medium used.

Bellows is also a great solution to use of process medium either with temperature below zero when ice accretions cause premature damage to packing or with high temperatures when bellows ensures medium cooling.

moves only in a portion of the stroke range at the inner centre of the valve, the service life of the bellows is many times longer then depending on concrete operating conditions.

Procedure for designing of two-way valve

Given: medium water, 155°C, static pressure at piping spot 1000 kPa (10 bar), $\Delta p_{DISP} = 80$ kPa (0,8 bar), $\Delta p_{PIPELINE} = 15$ kPa (0,15 bar), $\Delta p_{APPLIANCE} = 25$ kPa (0,25 bar), nominal flow rate $Q_{NOM} = 8$ m³.h⁻¹, minimal flow rate $Q_{MIN} = 1,3$ m³.h⁻¹.

$$\Delta p_{DISP} = \Delta p_{VALVE} + \Delta p_{APPLIANCE} + \Delta p_{PIPELINE}$$

$$\Delta p_{VALVE} = \Delta p_{DISP} - \Delta p_{APPLIANCE} - \Delta p_{PIPELINE} = 80 - 25 - 15 = 40 \text{ kPa (0,4 bar)}$$

$$Kv = \frac{Q_{NOM}}{\sqrt{\Delta p_{VALVE}}} = \frac{8}{\sqrt{0,4}} = 12,7 \text{ m}^3 \cdot \text{h}^{-1}$$

Precautionary additions for process tolerances (provided that flow rate Q was not oversized):

$$Kvs = (1,1 \text{ to } 1,3) \cdot Kv = (1,1 \text{ to } 1,3) \cdot 12,7 = 14 \text{ to } 16,5 \text{ m}^3 \cdot \text{h}^{-1}$$

Now we choose the nearest Kvs value from those available in our catalogue, i.e. $Kvs = 16$ m³.h⁻¹. This value corresponds to nominal size of DN 32. Then if we choose flanged execution PN 16, body made of spheroidal cast iron, with metal - PTFE seat sealing, packing PTFE and equal-percentage flow characteristic, we will get the following specification No.:

RV 21x XXX 1423 R1 16/220-32

x in the valve code above (RV21x) stands for valve execution (direct or reverse) and depends on type of used actuator which should be chosen in respect to demands of regulating system (type, producer, voltage, type of control, necessary torque or linear force, etc.).

Determination of real pressure drop value of a chosen valve at fully open

$$\Delta p_{VENTIL H100} = \left(\frac{Q_{NOM}}{Kvs} \right)^2 = \left(\frac{8}{16} \right)^2 = 0,25 \text{ bar (25 kPa)}$$

The control valve's real pressure drop calculated this way shall be taken into account in a hydraulic calculation of regulating circuit.

Determination of valve's real authority

$$a = \frac{\Delta p_{VALVE H100}}{\Delta p_{VALVE H0}} = \frac{25}{80} = 0,31$$

Value a should be at least equal to 0,3. A chosen valve checking is then satisfactory.

Caution: the valve's authority calculation should be related to a valve pressure difference in its closed position i.e. disposition pressure value in a branch Δp_{AVAIL} when flow rate is zero, not to a pressure value of a pump Δp_{PUMP} , because, due to pipeline circuit pressure drops up to the spot where the regulating branch is connected, the following equation applies: $\Delta p_{AVAIL} < \Delta p_{PUMP}$. In such cases we consider for simplicity the following: $\Delta p_{AVAIL H100} = \Delta p_{AVAIL H0} = \Delta p_{DISP}$.

Checking of rangeability

We carry out the same checking for minimal flow rate $Q_{MIN} = 1,3$ m³.h⁻¹. The following differential pressure values correspond to the min. flow rate: $\Delta p_{PIPELINE QMIN} = 0,40$ kPa, $\Delta p_{APPLIANCE QMIN} = 0,66$ kPa. $\Delta p_{VALVE QMIN} = 80 - 0,4 - 0,66 = 78,94 = 79$ kPa.

$$Kv_{MIN} = \frac{Q_{MIN}}{\sqrt{\Delta p_{VALVE QMIN}}} = \frac{1,3}{\sqrt{0,79}} = 1,46 \text{ m}^3 \cdot \text{h}^{-1}$$

Necessary rangeability value

$$r = \frac{Kvs}{Kv_{MIN}} = \frac{16}{1,46} = 11$$

shall be lower than mentioned rangeability value of $r = 50$. Checking is then satisfactory.

Selection of suitable flow characteristic

On the basis of calculated values Kv_{NOM} and Kv_{MIN} , it is possible to read the appropriate stroke values from the graph for individual types of flow characteristics of the valve and choose the most suitable one accordingly. Here we have $h_{NOM} = 96\%$ $h_{MIN} = 41\%$ for equal-percentage characteristic. In that case, LDM- spline® flow characteristic is more suitable (93% and 30% of the stroke). It corresponds to the following specification code :

RV 21x XXX 1423 S1 16/220-32

Scheme of typical regulation loop with the application of two-way control valve

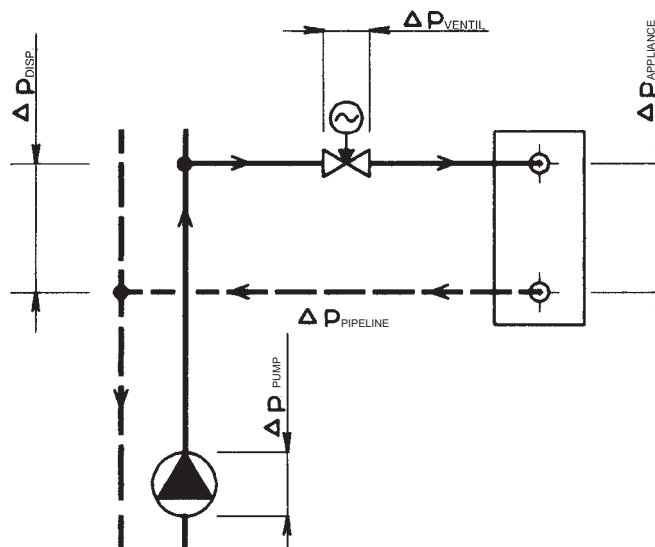

Remark: More detailed information on calculation and design of LDM control valves is mentioned in calculation instructions No. 01-12.0. Equations mentioned above apply in a simplified way to water. To reach optimum results, we recommend to use original calculation programme VALVES which is available on request free of charge.

Procedure for designing of three-way valve

Given: medium water, 90 °C, static pressure at piping spot 1000 kPa (10 bar), $\Delta p_{\text{PUMP2}} = 40$ kPa (0,4 bar), $\Delta p_{\text{PIPELINE}} = 10$ kPa (0,1 bar), $\Delta p_{\text{APPLIANCE}} = 20$ kPa (0,2 bar), flow rate $Q_{\text{NOM}} = 7 \text{ m}^3 \cdot \text{h}^{-1}$

$$\Delta p_{\text{PUMP2}} = \Delta p_{\text{VALVE}} + \Delta p_{\text{APPLIANCE}} + \Delta p_{\text{PIPELINE}}$$

$$\Delta p_{\text{VALVE}} = \Delta p_{\text{PUMP2}} - \Delta p_{\text{APPLIANCE}} - \Delta p_{\text{PIPELINE}} = 40 - 20 - 10 = 10 \text{ kPa (0,1 bar)}$$

$$Kv = \frac{Q_{\text{NOM}}}{\sqrt{\Delta p_{\text{VALVE}}}} = \frac{7}{\sqrt{0,1}} = 22,1 \text{ m}^3 \cdot \text{h}^{-1}$$

Precautionary additions for process tolerances (provided that flow rate Q was not oversized):

$$Kvs = (1,1 \text{ to } 1,3) \cdot Kv = (1,1 \text{ to } 1,3) \cdot 22,1 = 24,3 \text{ to } 28,7 \text{ m}^3 \cdot \text{h}^{-1}$$

Now we choose the nearest Kvs value from those available in our catalogue, i.e. $Kvs = 25 \text{ m}^3 \cdot \text{h}^{-1}$. This value corresponds to nominal size of DN 40. Then if we choose flanged execution PN 16, body made of spheroidal cast iron, with metal - PTFE seat sealing, packing PTFE and equal-percentage flow characteristic, we will get the following specification No.:

RV 21x XXX 1413 L1 16/140-40

x in the valve code above (21x) stands for valve execution (direct or reverse) and depends on type of used actuator which should be chosen in respect to demands of regulating system (type, producer, voltage, type of control, necessary torque or linear force, etc.)

Determination of real pressure drop value of a chosen valve at fully open

$$\Delta p_{\text{VALVE H100}} = \left(\frac{Q_{\text{NOM}}}{Kvs} \right)^2 = \left(\frac{7}{25} \right)^2 = 0,08 \text{ bar (8 kPa)}$$

The control valve's real pressure drop calculated this way shall be taken into account in a hydraulic calculation of regulating circuit.

Caution: To ensure reliable function of three-way valves, the most important condition is to keep minimum available pressure difference between A and B ports. Three-way valves are capable to manage even high pressure difference between A and B ports but valve's flow characteristic deformats then and so regulation properties deteriorate. So if in doubt about pressure difference value between those two ports (e.g. when three-way valve is piped directly into primary side without pressure separation), we recommend to use a two-way valve in combination with a primary-secondary side short cut to ensure a reliable regulation. The authority of A-AB way of three-way valve is, providing a constant flow rate in appliance circuit, the following:

$$a = \frac{\Delta p_{\text{VALVE H100}}}{\Delta p_{\text{VALVE H0}}} = \frac{8}{8} = 1,$$

which means that the behaviour of flow in A-AB way corresponds to ideal flow curve of the valve. In that case there are Kvs values in both ports the same with linear characteristic i.e. the total flow is nearly constant.

A combination of equal-percentage characteristic in A port and linear characteristic in B port shall be selected in those cases when loading of A port with differential pressure against B port cannot be avoided or when the primary side parameters are too high.

Scheme of a typical regulation loop with the application of a three-way mixing control valve

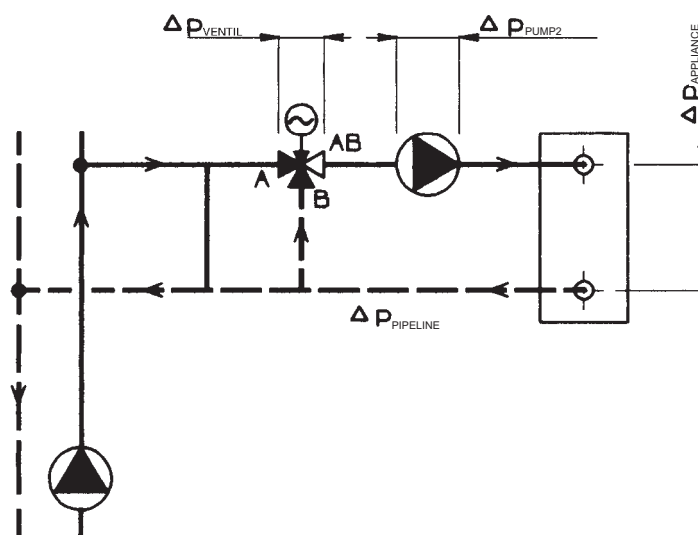

Remark: More detailed information on calculation and design of LDM control valves is mentioned in calculation instructions No. 01-12.0. Equations mentioned above apply in a simplified way to water. To reach optimum results, we recommend to use original calculation programme VALVES which is available on request free of charge.

RV 102 B RV 103 B



**Control valves
DN 15 - 50, PN 16
with Belimo actuators**

Description

Control valves series RV 102 are two-way or three-way valves with internal threaded connection. Valve body is made of brass. Control valves series RV 103 are two-way or three-way valves with flanged connection. Valve body is made of grey cast iron. Valves are optionally manufactured in the following executions:

- three-way control valve
- two-way, reverse control valve
- two-way, angular, control valve

Valves RV 102 B and RV 103 B are especially designed for Belimo actuators.

Application

Valves are designed for application in heating, ventilation or air conditioning systems for maximal temperature 150°C. Maximal permissible working pressures according to ČSN 13 0010, see page 18 of this catalogue.

Process media

Valve series RV 102 and RV 103 are designed to regulate the flow and pressure of liquids, gases and vapours without abrasive particles e.g. water, low-pressure steam (it applies to RV 102 only), air and other media compatible with material of the valve inner parts. Medium acidity and alkalinity should not exceed range of pH 4.5 to 9.5.

To ensure reliable regulation, producer recommends to pipe a strainer in front of the valve into pipeline.

Installation

The valve is to be piped the way so that the direction of medium flow will coincide with the arrows on the body (inlet ports A,B and outlet port AB).

In flow-diverting valves, the process medium flow is reversed (inlet port AB and outlet ports A, B).

Valve can be installed in any position except position when the actuator is under the valve body.

Technical data

Series	RV 102	RV 103
Type of valve	Three-way control valve Two-way, reversed control valve	
Nominal size range	DN 15 - 50	
Nominal pressure	PN 16	
Body material	Brass 42 3135	Grey cast iron EN-JL 1040
Plug material	Brass	
Operating temperature range	0 to 150°C	
Face to face dimensions	Section M4 Acc. to DIN 3202 (4/1982)	Section 1 acc. to ČSN-EN 558-1 (3/1997)
Connection	Internal threaded coupling Acc. to ČSN-ISO 229-1 (9/2003)	Type B1 (raised-faced) Acc. to ČSN-EN 1092-1 (4/2002)
Type of plug	V-ported plug	
Flow characteristic	Linear; equal-percentage	
Kvs values	0.6 to 40 m ³ /hour	
Leakage rate	Class III. acc. to ČSN-EN 1349 (5/2001) (<0.01 % Kvs) in way A-AB	
Rangeability	50 : 1	
Packing	O - ring EPDM	

Kvs values and differential pressures

Δp_{max} value is the valve maximal differential pressure when reliable opening and closing can be guaranteed. Because of seat and plug service life, it is recommended so that

permanent differential pressure would not exceed 0.6 MPa for valves RV 102 and 0.4 MPa for valves RV 103.

For further information on actuating, see actuators' catalogue sheets		Actuating (actuator)					NV24-3, NV230-3, NV24-MFT, NVF24-MFT, NVF24-MFT-E	
		Marking in valve specification No.					EBK	
		Linear force					800 N	
		Kvs [m ³ /hour]					Δp_{max}	
DN	H	1	2	3	4	5	MPa	
15	10	4.0	2.5	1.6	1.0	0.6	1.60	
20		6.3	4.0	2.5	---	---	1.60	
25		10.0	6.3	4.0	---	---	1.18	
32	16	16.0	10.0	6.3	---	---	0.73	
40		25.0	16.0	10.0	---	---	0.47	
50		40.0	25.0	16.0	---	---	0.28	

Dimensions and weights for the type RV 102

DN	C	L ₁	L ₂	L ₃	V ₁	V ₂	S	H	D	m
		mm	mm	mm	mm	mm	mm	mm	mm	kg
15	G 1/2	85	9	12	43	25	27	10	8	0.55
20	G 3/4	95	11	14	48	25	32			0.65
25	G 1	105	12	16	53	25	41			0.80
32	G 1 1/4	120	14	18	66	35	50	16	8	1.40
40	G 1 1/2	130	16	20	70	35	58			2.00
50	G 2	150	18	22	80	42	70			2.95

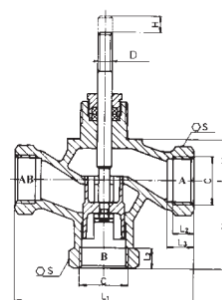

Dimensions and weights for the type RV 103

DN	D ₁	D ₂	D ₃	n x d	a	f	L ₁	V ₁	V ₂	H	D	m
	mm	mm	mm	mm	mm	mm	mm	mm	mm	mm	mm	kg
15	95	65	45	4x14	16	2	130	65	25	10	8	3.2
20	105	75	58				150	75	25			4.3
25	115	85	68				180	80	25			5.5
32	140	100	78	4x18	18	3	180	90	35	16	8	7.7
40	150	110	88				200	100	35			8.5
50	165	125	102				230	115	42			11.9

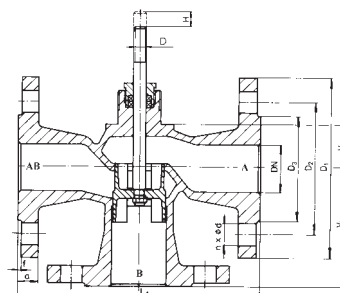

Valve complete specification No. for ordering

		XX	X X X	X X X	X X	X X	- XX	/	XXX	- XX
1. Type of valve	Control valve	RV								
2. Series	Valves made of brass		1 0 2							
	Valves made of grey cast iron		1 0 3							
3. Actuating	Electric actuator NV24-3 (24 V, 3-position control)			E B K						
¹⁾ Actuators with a fail-safe function	Electric actuator NV230-3 (230 V, 3-position control)			E B K						
	Electric actuator NV24-MFT (24 V, Multi-functional)			E B K						
	Electric actuator NVF24-MFT ¹⁾ (24 V, Multi-functional)			E B K						
	Electric actuator NVF24-MFT-E ¹⁾ (24 V, Multi-functional)			E B K						
4. Design	Straight, two-way, threaded valves				1					
	Angle, two-way, threaded valves	Applicable to RV 102			2					
	Mixing (diverting), three-way, threaded valves				3					
	Straight, two-way, flanged valves				4					
	Angle, two-way, flanged valves	Applicable to RV 103			5					
	Mixing (diverting), three-way, flanged valves				6					
5. Body material	Grey cast iron				3					
	Brass				5					
6. Flow characteristic	Linear				1					
	Equal-percentage ¹⁾				2					
7. Nominal Kvs value	Column No. acc. to Kvs values table				X					
8. Nominal pressure PN	PN 16						16			
9. Max. operating temperature °C								150		
10. Nominal size	DN									XX

Ordering example : Three-way control valves DN 25, PN 16 with electric actuator SQX 32.00, body material: brass, connection: internal thread G 1, linear flow characteristic, Kvs = 10 m³/hour is specified as follows : **RV 102 ELA 3511 16/140-25**

200 line

RV / HU 2x1 B



Control valves and Fail-safe action valves DN 15 - 65, PN 16 and 40 with Belimo actuators

Description

Control valves RV 211, RV 221 and RV 231 (further in text RV 2x1) are single-seated valves designed for regulation and shut-off of process medium flow. In regard of used actuators, the valves are suitable for regulation at lower differential pressures. Flow characteristics, Kvs values and leakage rates correspond to international standards.

Valves with a fail-safe action series HU 2x1 B have the same design as RV 2x1 with addition of increased seat sealing. Valves are equipped with fail-safe action actuators (valve closes or opens upon power failure).

Valves RV 2x1 B are especially designed for Belimo actuators.

Application

These valves have a wide range of application in heating, ventilation, power generation and chemical processing industries. Valve body can be optionally made of spheroidal cast iron, cast steel and austenitic stainless steel according to operating conditions.

The materials selected correspond to recommendations stipulated by ČSN-EN 1503-1 (1/2002) (steels) and ČSN-EN 1503-3 (1/2002) (cast). The maximum operating pressures for different materials are specified in the table on page 18 of this catalogue.

Process media

Valves series RV / HU 2x1 are designed for regulation (RV 2x1) and for regulation and shut-off (HU 2x1) of flow and pressure of liquids, gases and vapours without abrasive particles e.g. Water, steam, air and other media compatible with material of the valve inner parts. The application of valves made of spheroidal cast iron (RV 211) for steam is limited by the following parameters: Steam must be superheated (its dryness $x \geq 0,98$) and inlet pressure $p_1 \leq 0,4$ MPa when differential pressure is above-critical or $p_1 \leq 1,6$ MPa when differential pressure is under-critical. In case these values are exceeded, it is necessary to use valve made of cast steel (RV 221). To ensure reliable regulation, producer recommends to pipe a strainer in front of the valve or ensure in any other way that medium will not contain abrasive particles or impurities.

Installation

The valve is to be piped the way so that the direction of medium flow will coincide with the arrows on the body.

The valve can be installed in any position except position when the actuator is under the valve body. When medium temperature exceeds 150 °C, it is necessary to protect the actuator against glowing heat from the pipeline e.g. by the means of proper insulating of the pipeline and valve or by tilting the valve away from the heat radiation.

Technical data

Series	RV / HU 211	RV / HU 221	RV / HU 231
Type of valve	Two-way, single-seated, reverse, control valve		
Nominal size range	DN 15 to 65		
Nominal pressure	PN 16, PN 40		
Body material	Spheroidal cast iron EN-JS 1025 (EN-GJS-400-10-LT)	Cast steel 1.0619 (GP240GH) 1.7357 (G17CrMo5-5)	Stainless steel 1.4581 (GX5CrNiMoNb19-11-2)
Seat material : DN 15 - 50	1.4028 / 17 023.6	1.4028 / 17 023.6	1.4571 / 17 347.4
DIN W.Nr./ČSN DN 65	1.4027 / 42 2906.5	1.4027 / 42 2906.5	1.4581 / 42 2941.4
Plug material : DN 15 - 65	1.4021 / 17 027.6	1.4021 / 17 027.6	1.4571 / 17 347.4
DIN W.Nr./ČSN			
Operating temperature range	-20 to 180 °C	-20 to 180 °C	-20 to 180 °C
Face to face dimensions	Line 1 acc. to ČSN-EN 558-1 (3/1997)		
Flanges	Acc. to ČSN-EN 1092-1 (4/2002)		
Flange face	Type B1 (raised-faced) or Type F (female) acc. to ČSN-EN 1092-1 (4/2002)		
Type of plug	V-ported, parabolic, perforated		
Flow characteristic	Linear, equal-percentage, LDMspline®, parabolic		
Kvs value	0.4 to 63 m ³ /hour		
Leakage rate	Class III. acc. to ČSN-EN 1349 (5/2001) (<0.1% Kvs) for c. valves with metal-metal seat sealing Class IV. acc. to ČSN-EN 1349 (5/2001) (<0.01% Kvs) for c. valves with metal-PTFE seat sealing		
Rangeability r	50 : 1		
Packing	O - ring EPDM $t_{max}=140^{\circ}C$, DRSpack® (PTFE) $t_{max}=150^{\circ}C$, Bellows $t_{max}=180^{\circ}C$		

Remark: For low operating temperatures (-200 to +180 °C), it is possible to supply the valve RV / HU 231 with body material made of 1.4308 (cast stainless steel)

Kvs values and differential pressures

Δp_{max} value is the valve max. differential pressure when open-close function is always guaranteed. In regard of service life of seat and plug, it is recommended so that permanent

differential pressure would not exceed 1.6 MPa. Otherwise it is suitable to use perforated plug or sealing surfaces of seat and plug with a hard metal overlay.

For further information on actuating, see actuators' catalogue sheets		Actuating (actuator)						NV24-3, NV230-3, NV24-MFT, NVF24-MFT, NVF24-MFT-E	
		Marking in valve spec. No.						EBK	
		Linear force						800 N	
		Kvs [m ³ /hour]						Δp_{max}	
DN	H	1	2	3	4	5	6	metal	PTFE
15	20	---	2.5 ¹⁾	1.6 ¹⁾	1.0 ¹⁾	0.6 ¹⁾	0.4 ¹⁾	4.00	---
15		4.0 ¹⁾	---	---	---	---	---	3.40	---
20		---	---	2.5 ¹⁾	1.6 ¹⁾	1.0 ¹⁾	0.6 ¹⁾	4.00	---
20		---	4.0 ¹⁾	---	---	---	---	3.40	---
20		6.3 ¹⁾	---	---	---	---	---	1.56	---
25		---	---	---	2.5 ¹⁾	1.6 ¹⁾	1.0 ¹⁾	4.00	---
25		10.0	6.3 ²⁾	4.0 ²⁾	---	---	---	0.88	1.29
32		---	---	---	4.0 ¹⁾	---	---	3.40	---
32		16.0	10.0	6.3 ²⁾	---	---	---	0.45	0.77
40		25.0	16.0	10.0	---	---	---	0.23	0.49
50	40.0	25.0	16.0	---	---	---	0.10	0.29	
65	63.0	40.0	25.0	---	---	---	0.02	0.17	

1) parabolic plug

2) V-ported plug with linear characteristic, parabolic plug with equal-percentage, LDMspline® and parabolic characteristic.

Perforated plug available only with Kvs values in shadowed frames with the following restrictions:

- Kvs values 2.5 to 1.0 m³/hour available with linear characteristic only.
- Perforated plug with Kvs value acc. to column No. 2 available with linear or parabolic characteristic only.

metal - version with metal - metal seat sealing

PTFE - version with metal - PTFE seat sealing

Bellows packing can be used with V-ported plug only.

Equal-percentage, LDMspline® and parabolic characteristic available on condition : Kvs value ≥ 1.0

Max. differential pressure Δp for valves PN 16 must be 1.6 MPa.

Max. differential pressures specified in table apply to PTFE and O-ring packing. Δp_{max} for bellows must be consulted with the producer.

Dimensions and weights for the type RV 2x1

DN	PN 16					PN 40					PN 16, PN 40													
	D ₁	D ₂	D ₃	d	n	D ₁	D ₂	D ₃	d	n	D	f	D ₄	D ₅	L	V ₁	V ₂	[#] V ₂	V ₃	[#] V ₃	a	m ₁	m ₂	[#] m _v
	mm	mm	mm	mm		mm	mm	mm	mm		mm	mm	mm	mm	mm	mm	mm	mm	mm	mm	mm	kg	kg	kg
15	95	65	45	14	4	95	65	45	14	4	15	2	44	10	130	68	47	---	143	---	16	4.5	5.5	---
20	105	75	58			105	75	58			20				150	68	47	---	143	---	18	5.5	6.5	---
25	115	85	68			115	85	68			25				160	85	52	250	148	346	18	6.5	8	3.5
32	140	100	78			140	100	78			32				180	85	52	250	148	346	20	8	9.5	3.5
40	150	110	88			150	110	88			40				200	85	52	250	148	346	20	9	11	3.5
50	165	125	102			165	125	102			50				230	117	72	270	168	366	20	14	21	3.5
65	185	145	122			185	145	122			65				290	117	72	270	168	366	22	18	27	3.5

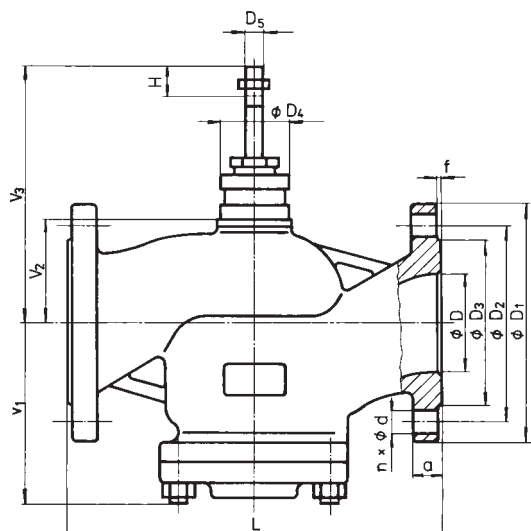

¹⁾ with regard of the standard previously in force, there is an option to have the number of connection bolts as stipulated in ČSN-EN 1092-1

^{#)} - for valve with bellows packing

m_v - weight to be added to weight of valve equipped with bellows packing

m₁ - for valves RV / HU 211

m₂ - for valves RV / HU 221 and RV / HU 231



Control valves and Fail-safe action valves DN 25 - 65, PN 16 and 40 with Belimo actuators

Description

Control valves RV 213, RV 223 and RV 233 (further in text RV 2x3) are single-seated valves with pressure-balanced plug designed for regulation and shut-off of process medium flow. Its design enables the valve to be applicable to regulation at high differential pressures with low-linear-force actuators. Flow characteristics, Kvs values and leakage rates correspond to international standards.

Valves with a fail-safe action series HU 2x3 B have the same design as RV 2x3 with addition of increased seat sealing. Valves are equipped with fail-safe action actuators (valve closes or opens upon power failure).

Valves RV 2x3 B are especially designed for Belimo actuators.

Application

These valves have a wide range of application in heating, ventilation, power generation and chemical processing industries. Valve body can be optionally made of spheroidal cast iron, cast steel and austenitic stainless steel according to operating conditions.

The materials selected correspond to recommendations stipulated by ČSN-EN 1503-1 (1/2002) (steels) and ČSN-EN 1503-3 (1/2002) (cast). The maximum operating pressures for different materials are specified in the table on page 18 of this catalogue.

Technical data

Series	RV / HU 213	RV / HU 223	RV / HU 233
Type of valve	Two-way, single-seated control valve with pressure-balanced plug		
Nominal size range	DN 15 to 65		
Nominal pressure	PN 16, PN 40		
Body material	Spheroidal cast iron EN-JS 1025 (EN-GJS-400-10-LT)	Cast steel 1.0619 (GP240GH) 1.7357 (G17CrMo5-5)	Stainless steel 1.4581 (GX5CrNiMoNb19-11-2)
Seat material : DN 15 - 50	1.4028 / 17 023.6	1.4028 / 17 023.6	1.4571 / 17 347.4
DIN W.Nr./ČSN DN 65	1.4027 / 42 2906.5	1.4027 / 42 2906.5	1.4581 / 42 2941.4
Plug material : DN 15 - 65	1.4021 / 17 027.6	1.4021 / 17 027.6	1.4571 / 17 347.4
DIN W.Nr./ČSN			
Operating temperature range	-20 to 180°C	-20 to 180°C	-20 to 180°C
Face to face dimensions	Line 1 acc. to ČSN-EN 558-1 (3/1997)		
Flanges	Acc. to ČSN-EN 1092-1 (4/2002)		
Flange face	Type B1 (raised-faced) or Type F (female) acc. to ČSN-EN 1092-1 (4/2002)		
Type of plug	V-ported, parabolic, perforated		
Flow characteristic	Linear, equal-percentage, LDMspline®, parabolic		
Kvs value	1.6 to 63 m ³ /hour		
Leakage rate	Class III. acc. to ČSN-EN 1349 (5/2001) (<0.1% Kvs) for c. valves with metal-metal seat sealing Class IV. acc. to ČSN-EN 1349 (5/2001) (<0.01% Kvs) for c. valves with metal-PTFE seat sealing		
Rangeability r	50 : 1		
Packing	O - ring EPDM t _{max} =150°C, DRSpack (PTFE) t _{max} =150°C, Bellows t _{max} =180°C		

Remark: For low operating temperatures (-200 to +180°C), it is possible to supply the valve RV / HU 231 with body material made of 1.4308 (cast stainless steel)

Process media

Valves series RV 2x3 are designed for regulation of flow and pressure of liquids, gases and vapours without abrasive particles e.g. Water, steam, air and other media compatible with material of the valve inner parts. The application of valves made of spheroidal cast iron (RV 213) for steam is limited by the following parameters: Steam must be superheated (its dryness $x_1 \geq 0,98$) and inlet pressure $p_1 \leq 0,4$ Mpa when differential pressure is above-critical or $p_1 \leq 1,6$ MPa when differential pressure is unde-critical. In case these values are exceeded, it is necessary to use valve made of cast steel (RV 223). To ensure reliable regulation, producer recommends to pipe a strainer in front of the valve or ensure in any other way that medium will not contain abrasive particles or impurities.

Installation

The valve is to be piped the way so that the direction of medium flow will coincide with the arrows on the body.

The valve can be installed in any position except position when the actuator is under the valve body. When medium temperature exceeds 150°C, it is necessary to protect the actuator against glowing heat from the pipeline; e.g. by the means of proper insulating of the pipeline and valve or by tilting the valve away from the heat radiation.

Kvs values and differential pressures

Δp_{max} value is the valve max. differential pressure when open-close function is always guaranteed. In regard of service life of seat and plug, it is recommended so that permanent

differential pressure would not exceed 1.6 MPa. Otherwise it is suitable to use perforated plug or sealing surfaces of seat and plug with a hard metal overlay.

For further information on actuating, see actuators' catalogue sheets		Actuating (actuator)			NV24-3, NV230-3, NV24-MFT, NVF24-MFT, NVF24-MFT-E			
		Marking in valve spec. No.			EBK			
		Linear force			800 N			
		Kvs [m ³ /hour]			Δp_{max}			
DN	H	1	2	3	metal		PTFE	
25	20	10	6.3 ¹⁾	4.0 ¹⁾	1.60	(1.60)	1.60	(1.60)
32		16.0	10.0	6.3 ¹⁾	1.60	(1.60)	1.60	(1.60)
40		25.0	16.0	10.0	1.60	(1.60)	1.60	(1.60)
50		40.0	25.0	16.0	1.60	(0.94)	1.60	(1.60)
65		63.0	40.0	25.0	1.60	(0.25)	1.60	(1.60)

1) linear characteristic only

Perforated plug available only with Kvs values in shadowed frames with the following restrictions:

- Perforated plug with Kvs value acc. to column No. 2 available with linear or parabolic characteristic only.

metal - version with metal - metal seat sealing

PTFE - version with metal - PTFE seat sealing

(xx) - Δp_{max} values specified in parentheses apply to perforated plug

Max. differential pressures specified in table apply to PTFE and O-ring packing. Δp_{max} for bellows must be consulted with the producer.

Max. differential pressure Δp for valves PN 16 must be 1.6 MPa.

Dimensions and weights for the type RV 2x3

DN	PN 16					PN 40					PN 16, PN 40													
	D ₁	D ₂	D ₃	d	n	D ₁	D ₂	D ₃	d	n	D	f	D ₄	D ₅	L	V ₁	V ₂	[#] V ₂	V ₃	[#] V ₃	a	m ₁	m ₂	[#] m _v
	mm	mm	mm	mm		mm	mm	mm	mm		mm	mm	mm	mm	mm	mm	mm	mm	mm	mm	mm	kg	kg	kg
25	115	85	68	14		115	85	68	14		25				160	85	52	250	148	346	18	7	8.5	3.5
32	140	100	78			140	100	78		4	32				180	85	52	250	148	346	18	8.5	10	3.5
40	150	110	88	18	4	150	110	88	18	4	40	2	44	10	200	85	52	250	148	346	18	8.5	10	3.5
50	165	125	102			165	125	102			50				230	117	72	270	168	366	20	14.5	21	3.5
65	185	145	122	4 ¹⁾		185	145	122		8	65				290	117	72	270	168	366	22	18.5	27	3.5

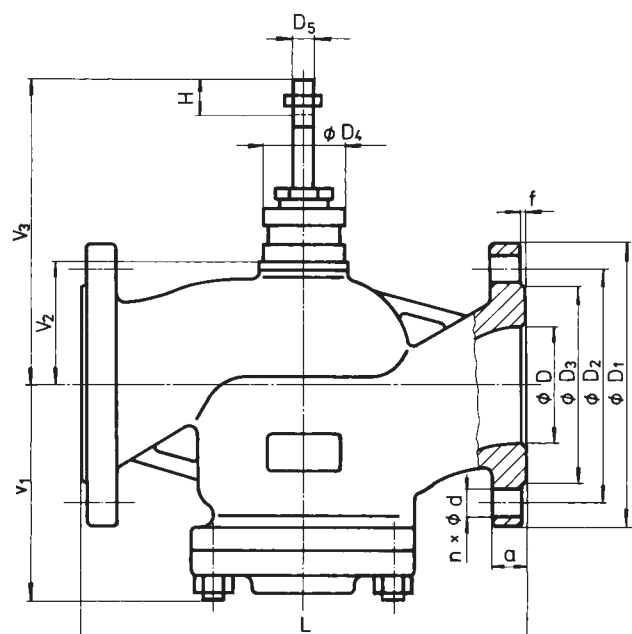

¹⁾ with regard of the standard previously in force, there is an option to have the number of connection bolts as stipulated in ČSN-EN 1092-1

^{#)} - for valve with bellows packing

m₁ - weight to be added to weight of valve equipped with bellows packing

m_v - for valves RV / HU 211

m₂ - for valves RV / HU 221 and RV / HU 231



200 line

RV 2x5 B

**Control valves
DN 15 - 65, PN 16 and 40
with Belimo actuators**

Description

Control valves RV 215, RV 225 and RV 235 (further only RV 2x5) are three-way valves with mixing or flow-diverting function. In regard of used actuators, the valves are suitable for regulation at lower differential pressures. Flow characteristics, Kvs values and leakage rates correspond to international standards.

When assembled with a fail-safe action actuator, it closes straight way upon power failure.

Valves RV 2x5 B are especially designed for Belimo actuators.

Application

These valves have a wide range of application in heating, ventilation, power generation and chemical processing industries. Valve body can be optionally made of spheroidal cast iron, cast steel and austenitic stainless steel according to operating conditions.

The materials selected correspond to recommendations stipulated by ČSN-EN 1503-1 (1/2002) (steels) and ČSN-EN 1503-3 (1/2002) (cast). The maximum operating pressures for different materials are specified in the table on page 18 of this catalogue.

Process media

Valves series RV 2x5 are designed for regulation of flow and pressure of liquids, gases and vapours without abrasive particles e.g. water, steam, air and other media compatible with material of the valve inner parts. The application of valves made of spheroidal cast iron (RV 215) for steam is limited by the following parameters: Steam must be superheated (its dryness $x_1 \geq 0,98$) and inlet pressure $p_1 \leq 0,4$ MPa when differential pressure is above-critical or $p_1 \leq 1,6$ MPa when differential pressure is under-critical. In case these values are exceeded, it is necessary to use valve made of cast steel (RV 225). To ensure reliable regulation, producer recommends to pipe a strainer in front of the valve or ensure in any other way that medium will not contain abrasive particles or impurities.

Installation

When the valve is used as mixing, it must be piped the way so that direction of process medium flow will coincide with the arrows on the body (inlet ports A, B and outlet port AB). When the valves is used as diverting, process medium flows through common valve port AB and split streams leave through valve ports A and B.). The valve can be installed in any position except position when the actuator is under the valve body. When medium temperature exceeds 150°C, it is necessary to protect the actuator against glowing heat from the pipeline; e.g. by the means of proper insulating of the pipeline and valve or by tilting the valve away from the heat radiation.

Technical data

Series	RV / HU 215	RV / HU 225	RV / HU 235
Type of valve	Three-way reversed control valve		
Nominal size range	DN 15 to 65		
Nominal pressure	PN 16, PN 40		
Body material	Spheroidal cast iron EN-JS 1025 (EN-GJS-400-10-LT)	Cast steel 1.0619 (GP240GH) 1.7357 (G17CrMo5-5)	Stainless steel 1.4581 (GX5CrNiMoNb19-11-2)
Seat material : DN 15 - 50	1.4028 / 17 023.6	1.4028 / 17 023.6	1.4571 / 17 347.4
DIN W.Nr./ČSN DN 65	1.4027 / 42 2906.5	1.4027 / 42 2906.5	1.4581 / 42 2941.4
Plug material : DN 15 - 65	1.4021 / 17 027.6	1.4021 / 17 027.6	1.4571 / 17 347.4
DIN W.Nr./ČSN			
Operating temperature range	-20 to 180°C	-20 to 180°C	-20 to 180°C
Face to face dimensions	Line 1 acc. to ČSN-EN 558-1 (3/1997)		
Flanges	Acc. to ČSN-EN 1092-1 (4/2002)		
Flange face	Type B1 (raised-faced) or Type F (female) acc. to ČSN-EN 1092-1 (4/2002)		
Type of plug	V-ported, parabolic, perforated		
Flow characteristic	Linear, equal-percentage in AB - B way		
Kvs value	1.6 to 63 m ³ /hour		
Leakage rate	Class III. acc. to ČSN-EN 1349 (5/2001) (<0.1% Kvs) for c. valves with metal-metal seat sealing Class IV. acc. to ČSN-EN 1349 (5/2001) (<0.01% Kvs) for c. valves with metal-PTFE seat sealing		
Rangeability r	50 : 1		
Packing	O - ring EPDM $t_{max}=150^{\circ}C$, DRSpack® (PTFE) $t_{max}=150^{\circ}C$, Bellows $t_{max}=180^{\circ}C$		

Remark: For low operating temperatures (-200 to +180°C), it is possible to supply the valve RV / HU 231 with body material made of 1.4308 (cast stainless steel)

Kvs values and differential pressures

Δp_{max} value is the valve max. differential pressure when open-close function is always guaranteed. In regard of service life of seat and plug, it is recommended so that permanent

differential pressure would not exceed 1.6 MPa. Otherwise it is suitable to use perforated plug or sealing surfaces of seat and plug with a hard metal overlay.

For further information on actuating, see actuators' catalogue sheets		Actuating (actuator)			NV24-3, NV230-3, NV24-MFT, NVF24-MFT, NVF24-MFT-E	
		Marking in valve spec. No.			EBK	
		Linear force			800 N	
DN	H	Kvs [m ³ /hour]			Δp_{max}	
		1	2	3	metal	PTFE
15	20	---	2.5 ¹⁾	1.6 ¹⁾	4.00	---
15		4.0 ¹⁾	---	---	3.40	---
20		---	---	2.5 ¹⁾	4.00	---
20		---	4.0 ¹⁾	---	3.40	---
20		6.3 ¹⁾	---	---	1.56	---
25		10.0	6.3 ²⁾	4.0 ²⁾	0.88	1.29
32		16.0	10.0	6.3 ²⁾	0.45	0.77
40		25.0	16.0	10.0	0.23	0.49
50		40.0	25.0	16.0	0.10	0.29
65		63.0	40.0	25.0	0.02	0.17

- 1) parabolic plug in straight way, V-ported plug in angle way
- 2) V-ported plug in angle way, in straight way for linear characteristic V-ported plug and for equal-percentage characteristic parabolic plug.

metal - version with metal - metal seat sealing
PTFE - version with metal - PTFE seat sealing

Max. differential pressures specified in table apply to PTFE and O-ring packing. Δp_{max} for bellows must be consulted with the producer.

Bellows packing can be used with V-ported plug only.

Max. differential pressure Δp for valves PN 16 must be 1.6 MPa.

Dimensions and weights for the type RV 2x5

DN	PN 16					PN 40					PN 16, PN 40													
	D ₁	D ₂	D ₃	d	n	D ₁	D ₂	D ₃	d	n	D	f	D ₄	D ₅	L	V ₁	V ₂	#V ₂	V ₃	#V ₃	a	m ₁	m ₂	#m _v
	mm	mm	mm	mm		mm	mm	mm	mm		mm	mm	mm	mm	mm	mm	mm	mm	mm	mm	mm	kg	kg	kg
15	95	65	45	14	4	95	65	45	14	4	15	2	44	10	130	110	47	---	143	---	16	5.5	6	---
20	105	75	58			105	75	58			20				150	115	47	---	143	---	18	6.5	7	---
25	115	85	68			115	85	68			25				160	130	52	250	148	346	18	8.3	9.5	3.5
32	140	100	78			140	100	78			32				180	135	52	250	148	346	20	10.5	12	3.5
40	150	110	88	18	8	150	110	88	18	8	40	65		200	140	52	250	148	346	20	12	13.5	3.5	
50	165	125	102			165	125	102			50			230	175	72	270	168	366	20	17	24	3.5	
65	185	145	122			185	145	122			65			290	180	72	270	168	366	22	22	31	3.5	

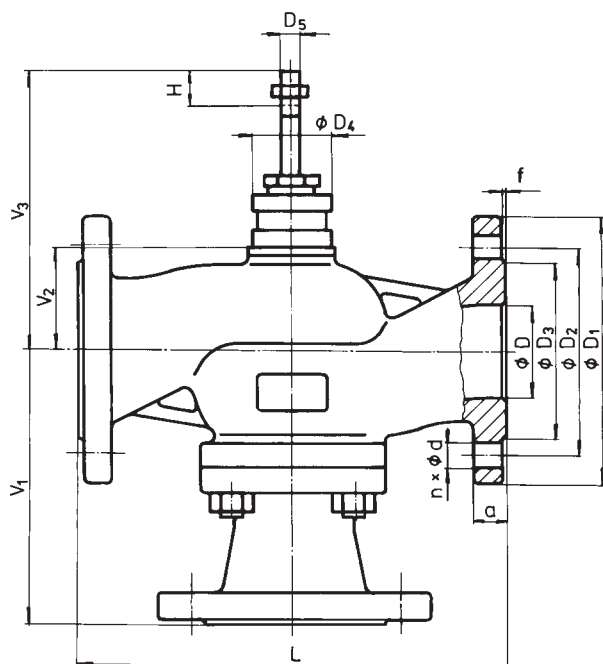

¹⁾ with regard of the standard previously in force, there is an option to have the number of connection bolts as stipulated in ČSN-EN 1092-1

^{#)} - for valve with bellows packing

m_v - weight to be added to weight of valve equipped with bellows packing

m₁ - for valves RV 215

m₂ - for valves RV 225 and RV 235

Valve complete specification No. for ordering RV / HU 2x1, RV 2x3, RV 2x5

		XX	XX X	XX X	XX X X	XX	- XX	/ XXX	- XXX
1. Valve	Control valve	RV							
	Fail-safe action valve	HU							
2. Series	Valves made of sph. cast iron EN-JS 1025								
	Valves made of cast steel 1.0619, 1.7357	2	2						
	Valves made of stainless steel 1.4581	2	3						
	Reverse valve			1					
	Pressure-balanced, reverse valve			3					
	Mixing (diverting), reverse valve			5					
3. Actuating ¹⁾ Actuators with a fail-safe function	Electric actuator				E				
	NV24-3 (24 V, 3-position)				E B K				
	NV230-3 (230 V, 3-position)				E B K				
	NV24-MFT (24 V, Multi-functional)				E B K				
	NVF24-MFT ¹⁾ (24 V, Multi-functional)				E B K				
	NVF24-MFT-E ¹⁾ (24 V, Multi-functional)				E B K				
4. Connection	Raised flange				1				
	Female flange				2				
5. Body material <i>(Operating temperature ranges are specified in parentheses)</i>	Cast steel 1.0619 (-20 to 400°C)				1				
	Sphr. cast iron EN-JS 1025 (-20 to 300°C)				4				
	CrMo steel 1.7357 (-20 to 500°C)				7				
	Stained steel 1.4581 (-20 to 400°C)				8				
	Other material on request				9				
6. Seat sealing ³⁾ from DN 25; $t_{max} = 260^{\circ}C$	Metal - metal				1				
	Soft sealing (metal - PTFE) in straight way ³⁾				2				
	Hard metal overlay on sealing surfaces				3				
7. Packing	O - ring EPDM				1				
	DRSpack® (PTFE)				3				
	Bellows				7				
	Bellows with safety PTFE packing				8				
8. Flow characteristic ⁴⁾ Not applicable to RV 2x5	Linear					L			
	Equal-percentage in straight way					R			
	LDMspline® ⁴⁾					S			
	Parabolic ⁴⁾					P			
	Linear - perforated plug ⁴⁾					D			
	Equal-percentage - perforated plug ⁴⁾					Q			
	Parabolic - perforated plug ⁴⁾					Z			
9. Kvs	Column No. acc. to Kvs values table					X			
10. Nominal pressure PN	PN 16						16		
	PN 40						40		
11. Max. operating temp. °C ⁵⁾ Not applicable to RV / HU 2x3	O - ring EPDM							140	
	DRSpack® (PTFE)							150	
	Bellows							180	
12. Nominal size DN	DN								XXX

Ordering example: Two-way control valve DN 65, PN 40, with electric actuator NV230-3, body material: spheroidal cast iron, flange with raised face, metal-metal seat sealing, PTFE packing, linear characteristic, Kvs = 63 m³/hour is specified as follows: **RV 211 EBK 1413 L1 40/150-65**

Valves RV / HU 2x1

Section of valve with V-ported plug

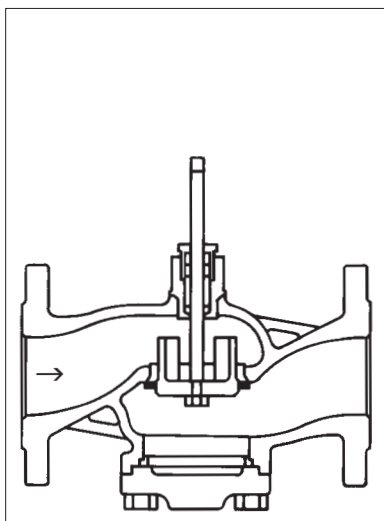

Section of valve with perforated plug

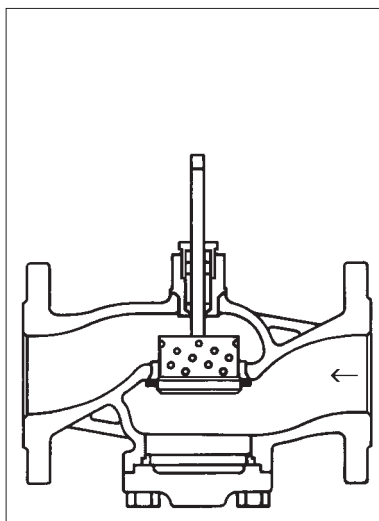

Valves RV / HU 2x3

Section of pressure-balanced valve with V-ported plug

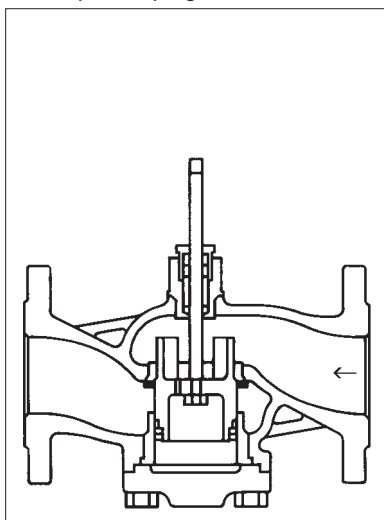

Section of pressure-balanced valve with perforated plug

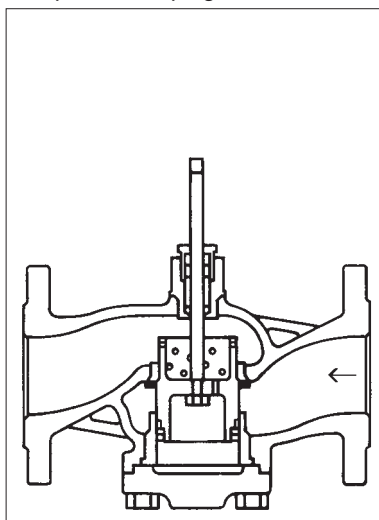

Valves RV 2x5

Section of three-way valve with V-ported plug

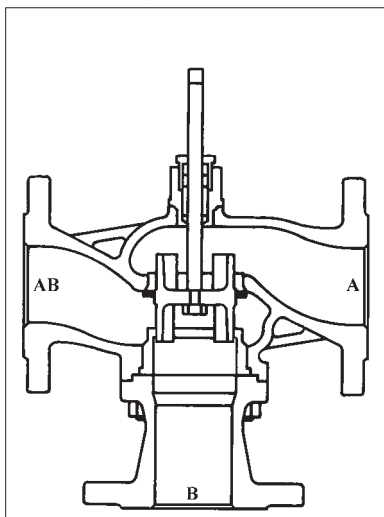

**Electric actuators
NV...
Belimo**
Technical data

Type	NV24-3	NV230-3	NV24-MFT	NVF24-MFT	NVF24-MFT-E
Marking in valve specification No.	EBK				
Voltage	AC/DC 24 V	AC 230 V	AC/DC 24 V		
Frequency	50...60 Hz				
Motor power	3 W		5 W	5,5 W	
Control	3 - position		0 - 10 V (3 - position, ON - OFF)		
Running time	150 s (90 s)		150 s (95 to 2000 s)		
Fail-safe mode	---			30 s	
Fail-safe function	---			indirect	direct
Nominal force	800 N				
Travel	2 to 20 mm				
Enclosure	IP 54				
Process medium max. temperature	+5 ... 150°C (with bellows 180°C)				
Ambient temperature range	0 to 50°C				
Ambient humidity limit	5 ... 95 %				
Weight	1,5 kg				

Direct and indirect function of actuator

Direct function ensures that actuator stem extends (the valve opens) upon power supply failure.
Indirect function ensures that actuator stem retracts (the valve closes) upon power supply failure.

Multi-functional technology MFT

Due to a built-in microprocessor, some of the actuator's parameters can be set by the user, e.g.: type of control signal, running time, tripping torque value, etc. The configuration is carried out with PC or a special programming device.

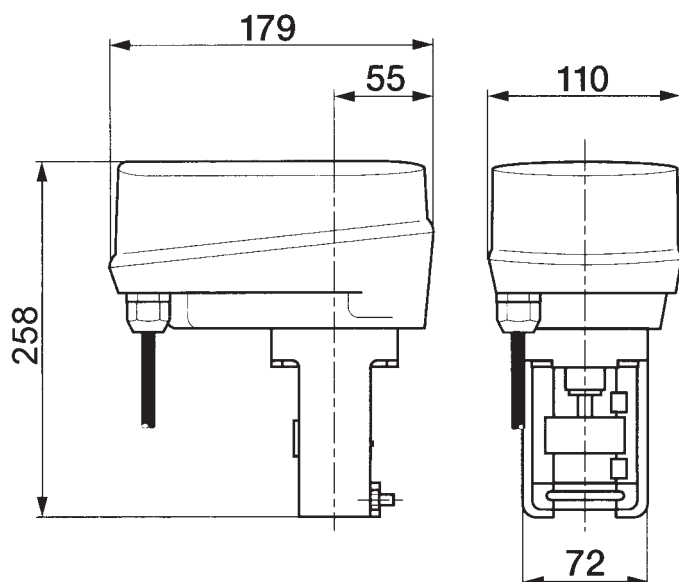
Dimensions of actuator

Wiring diagrams of actuators

NV24-3 and NV230-3

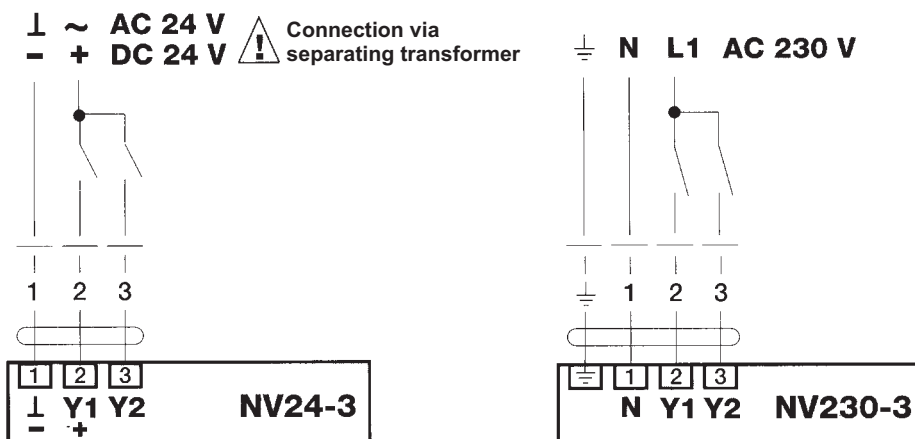

NV24-MFT

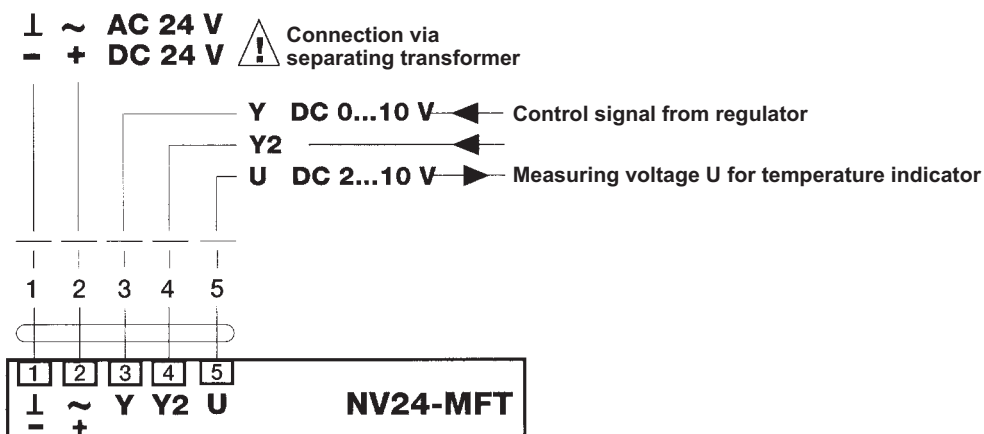

NVF24-MFT and NVF24-MFT-E

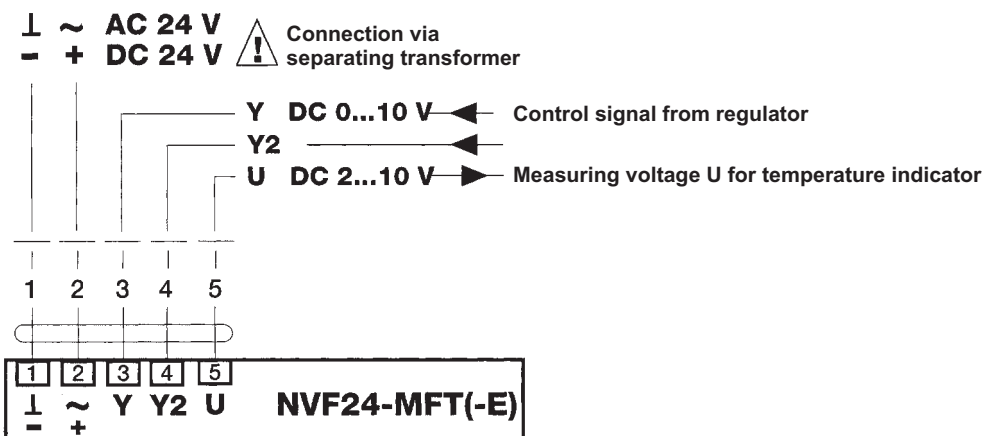

Maximal permissible operating pressures [MPa]

Material	PN	Temperature [°C]										
		120	150	200	250	300	350	400	450	500	525	550
Brass 42 3135	16	1,60	1,14	---	---	---	---	---	---	---	---	---
		---	---	---	---	---	---	---	---	---	---	---
Grey cast iron EN-JL 1040 (EN-GJL-250)	16	1,60	1,44	---	---	---	---	---	---	---	---	---
		---	---	---	---	---	---	---	---	---	---	---
Spher.cast iron EN-JS 1025 (EN-GJS-400-18-LT)	16	1,50	1,40	1,40	1,30	1,10	---	---	---	---	---	---
	40	4,00	3,88	3,60	3,48	3,20	---	---	---	---	---	---
Cast steel 1.0619 (GP240GH)	16	1,60	1,50	1,40	1,30	1,10	1,00	0,80	---	---	---	---
	40	4,00	4,00	3,90	3,60	3,20	2,70	1,90	---	---	---	---
Chrommolybden steel 1.7357 (G17CrMo5-5)		---	---	---	---	---	---	---	---	---	---	---
	40	4,00	4,00	4,00	4,00	4,00	4,00	3,90	3,10	1,80	---	---
Stainless steel 1.4581 (GX5CrNiMoNb19-11-2)	16	1,60	1,50	1,40	1,30	1,30	1,20	1,20	---	---	---	---
	40	4,00	3,80	3,50	3,40	3,30	3,10	3,00	---	---	---	---

Notes:



LDM, spol. s r.o.
Litomyšlská 1378
560 02 Česká Třebová
Czech Republic

tel.: +420 465 502 511
fax: +420 465 533 101
E-mail: sale@ldm.cz
<http://www.ldm.cz>

LDM, spol. s r.o.
Büro Prague
Tiskařská 10
108 28 Praha 10 - Malešice
Czech Republic

tel.: +420 234 054 190
fax: +420 234 054 189

LDM, spol. s r.o.
Büro Ústí nad Labem
Mezní 4
400 11 Ústí nad Labem
Czech Republic

tel.: +420 475 650 260
fax: +420 475 650 263

LDM servis, spol. s r.o.
Litomyšlská 1378
560 02 Česká Třebová
Czech Republic

tel.: +420 465 502 411-3
fax: +420 465 531 010
E-mail: servis@ldm.cz

LDM, Polska Sp. z o.o.
Modelarska 12
40 142 Katowice
Poland

tel.: +48 32 730 56 33
fax: +48 32 730 52 33
mobile: +48 601 354999
E-mail:
ldmpolska@ldm.cz

LDM Bratislava s.r.o.
Mierová 151
821 05 Bratislava
Slovakia

tel.: +421 2 43415027-8
fax: +421 2 43415029
E-mail: ldm@ldm.sk
<http://www.ldm.sk>

LDM - Bulgaria - OOD
z. k. Mladost 1
bl. 42, floor 12, app. 57
1784 Sofia
Bulgaria

tel.: +359 2 9746311
fax: +359 2 9746311
GSM: +359 88 925766
E-mail: ldm.bg@mbox.cit.bg

OAO "LDM"
Chernyakhovskogo str., build. 4
125319 Moskau
Russian Federation

tel.: +7 095 7973037
fax: +7 095 7973037
E-mail: inforus@ldmvalves.com

LDM Armaturen GmbH
Wupperweg 21
D-51789 Lindlar
Germany

tel.: +49 2266 440333
fax: +49 2266 440372
mobile: +49 177 2960469
E-mail: ldmarmaturen@ldmvalves.com
<http://www.ldmvalves.com>

Your partner